



PRECISION IN EVERY DETAIL



DUY TAN PRECISION MOLD



Company Overview

SNAPSHOTS

- ▶ Taken apart from DUYTAN group since 2017.
- ▶ Twenty-two-year experiences in plastic mold design and manufacture, provide our customers comprehensive solution through closed processes from mold design, making mold, testing samples, manufacturing plastic products with injection and blowing processes, printing, labeling and delivery.
 - ▶ Annual output: 240 - 300 high quality sets.
 - ▶ 2019: Certificate on High Technology Enterprise issued by Ministry of Science & Technology.

Highlights

- *HQ Area: 8,250 m²*
- *Existing staff: 120 ppl (35 engineers)*
- *Main products: Precision molds*
- *Capacity: 240 - 300 sets/year*
- *Mold warrantee policy: up to 2 million shots depend on customer requirements.*
- *Mold precision: $\leq 5 - 10 \mu\text{m}$*



Company Overview

VISION

- *To become a leading mold supplier in South East Asia.*

MISSION

- *To produce exquisite and high quality plastic products that meet our customers' requirements*

CORE VALUES

- *Creation – Speed – Quality – Discipline*



OUR SERVICES

- Product design & concept to realization: Solution & 2D & 3D
- Reverse engineering & rapid prototype
- Mold design: analysis DFM (Design For Manufacturing), Moldflow Insight simulation
- Pilot mold manufacturing
- Production mold manufacturing
- Mold qualification



SEGMENTS SERVED

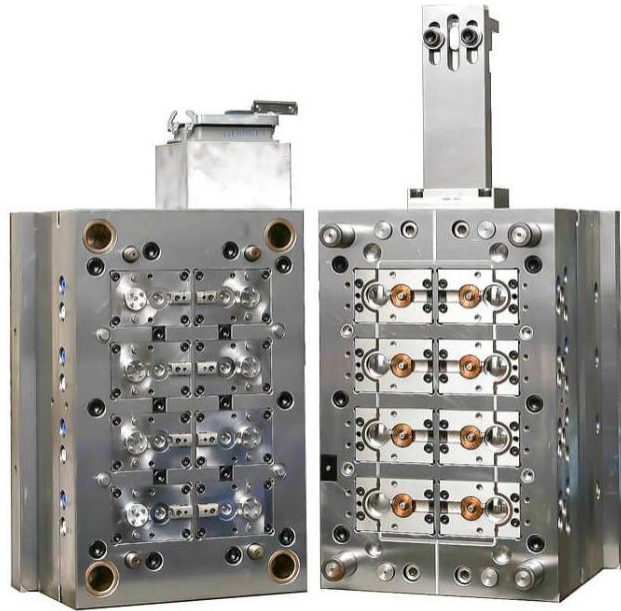

Injection molds for Caps &
Closures

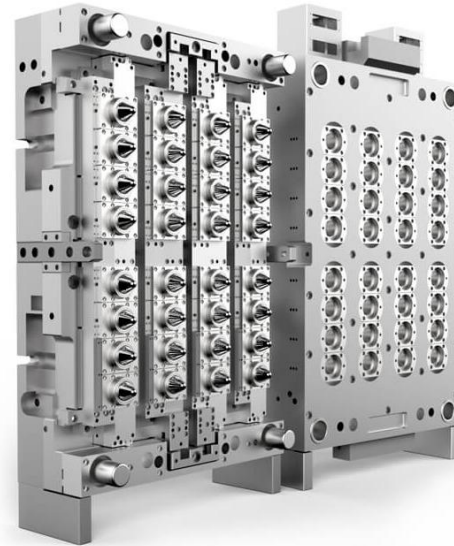

Injection molds for
preform packaging



Blowing molds for cosmetics jars /
bottles

A produces about 300 sets of high precision molds per year



Our Partners & Customers

<p>MACHINES/ EQUIPMENTS</p>						
<p>SOFTWARES</p>						
<p>CUSTOMERS</p>						
						



MOLD MANUFACTURING OVERVIEW



CUSTOMER
REQUEST

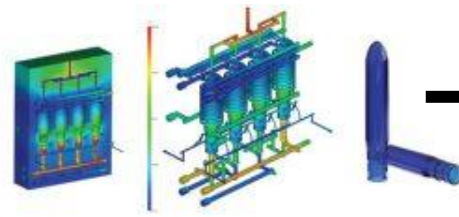

MOLDFLOW
SIMULATION

MOLD DESIGN

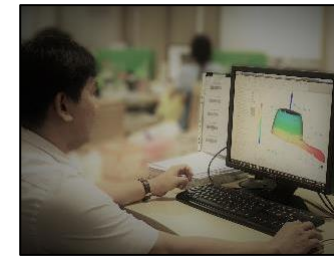

MOLD
MANUFACTURING



MOLD TRIAL



DELIVERY/
HAND
OVER



QA/QC AND
ACCEPTANCE



MOLD
ADJUSTMENT





ANALYSIS & DESIGNING PROCESS

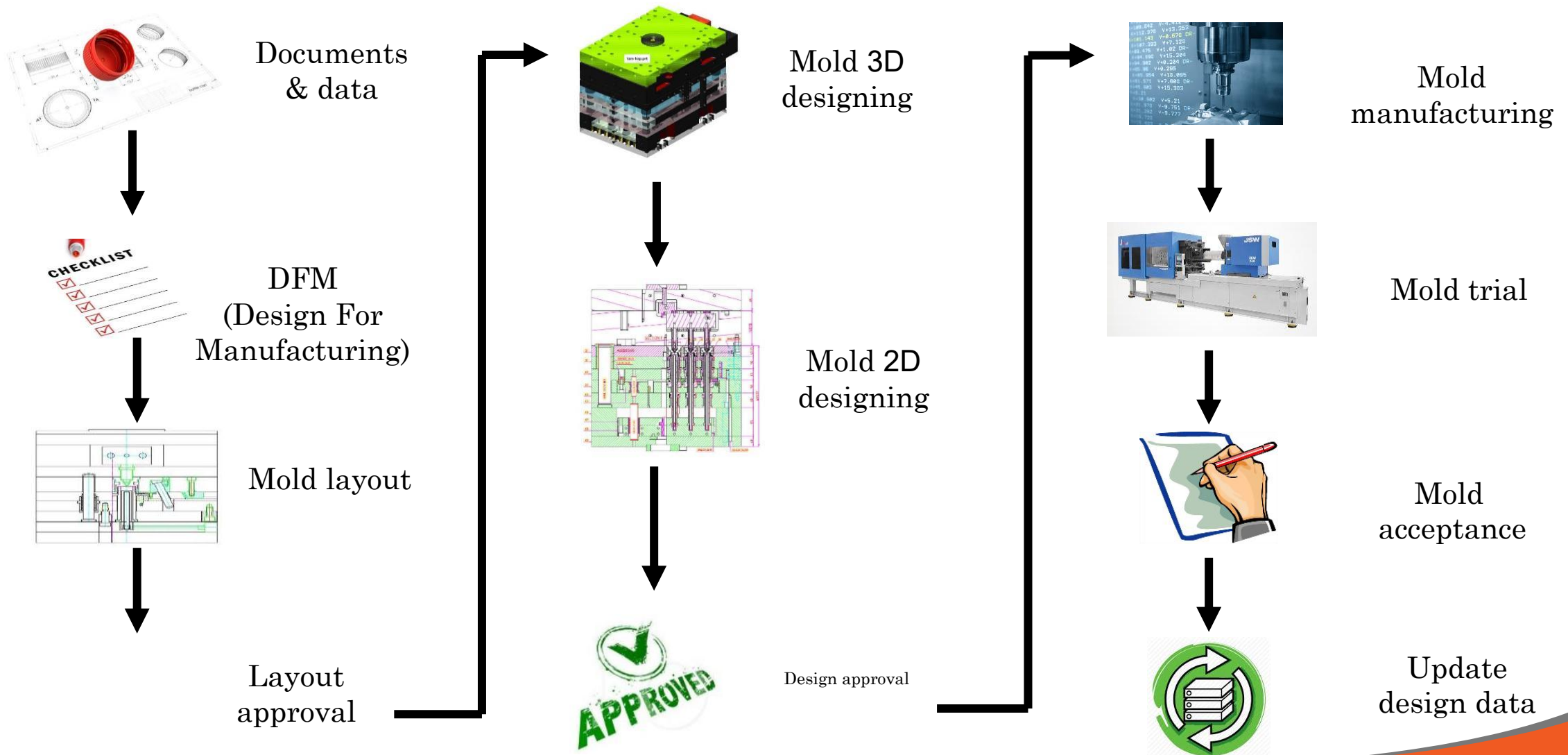



MANUFACTURING PROCESSING

Steel & materials

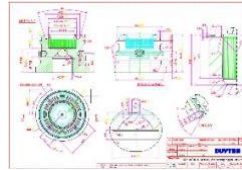
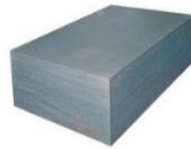

Manufacturing processing analysis basing on 3D&2D

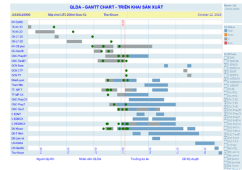

Processing scheduling



Mold components

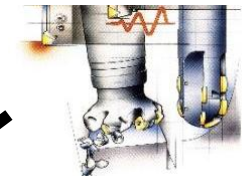

Rough machining
(Raw steel, rough milling & turning)



Mold completing
(QC, polishing, assembly)



Inserts finish machining
(Milling, turning, EDM, grinding, ...)



DESIGNING & PROCESS PROGRAMMING

- R&D: **6** engineers
- Designing & process programming: **13** engineers
- Technical analysis & design:
 - Pro Creo
 - Unigraphics
 - Hyper Mill
 - AutoCAD 2018
 - Mold Flow Insight 2021

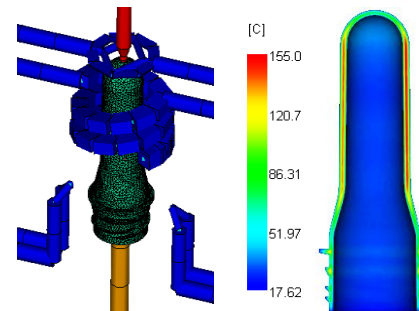
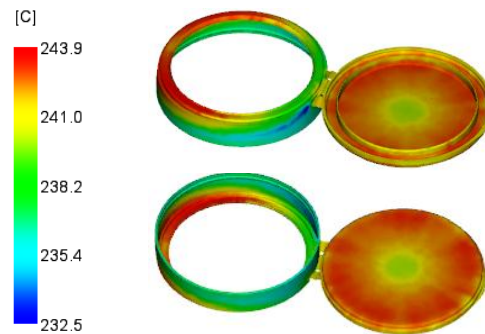



TECHNOLOGY



- Human : 120
- CNC milling : 12 machines
- CNC lathe : 7 machines
- EDM & WEDM : 7 machines



Processing: Rough & Finish Machining

*Milling machine
CNC MAZAK
FJV-35/80II*



*Milling machine
CNC MAZAK-
FJV-60/80II*



*Milling machine
CNC MAZAK-
VCS530*



Gun Drill machine





Processing: Grinding



Flat grinding machine
Okamoto ACC450



Circular grinding machine
Palmary GU32X60S



Processing: Finish Machining



Milling machines CNC 5 axis
Makino D500 (Japan)

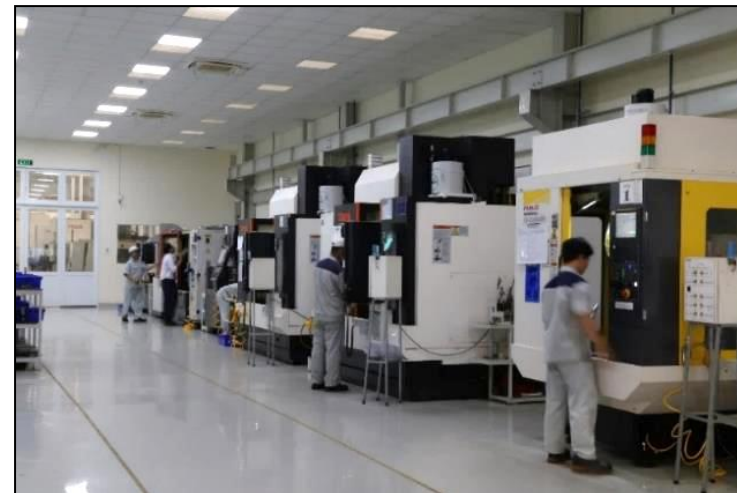



Processing: Finish Machining

LATHE MACHINE CNC MAZAK

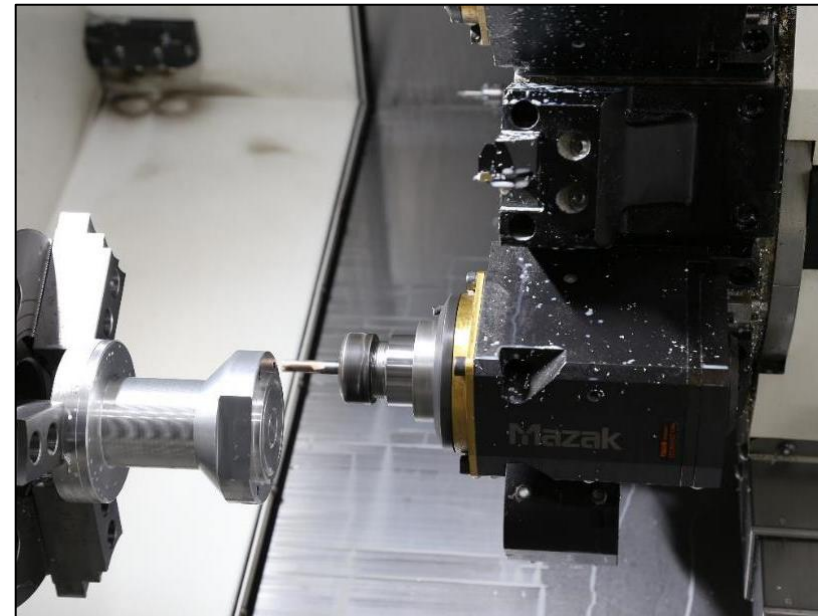

Lathe machine CNC Mazak QT300 MA, with C milling axis (Japan)



Processing: Finish Machining

EDM MACHINES



EDM Charmilles Roboform 35P
(Switzerland)



EDM Sodick AG40L
(Japan)



Processing: Finish Machining

WEDM MACHINES



Charmilles Robofil 380 (Switzerland)



Makino U3 (Japan)



MOLD TESTING MACHINES



JSW (JAPAN)



Krauss Maffei (GERMANY)



QUALITY ASSURANCE



**Coordinate
Measuring Machine
(CMM) - Mitutoyo**



**Projector Measuring -
Mitutoyo**



**Height measuring
machine - Zoller**



**Hardness
testing machine**



CAP & CLOSURE





INJECTION MOLD

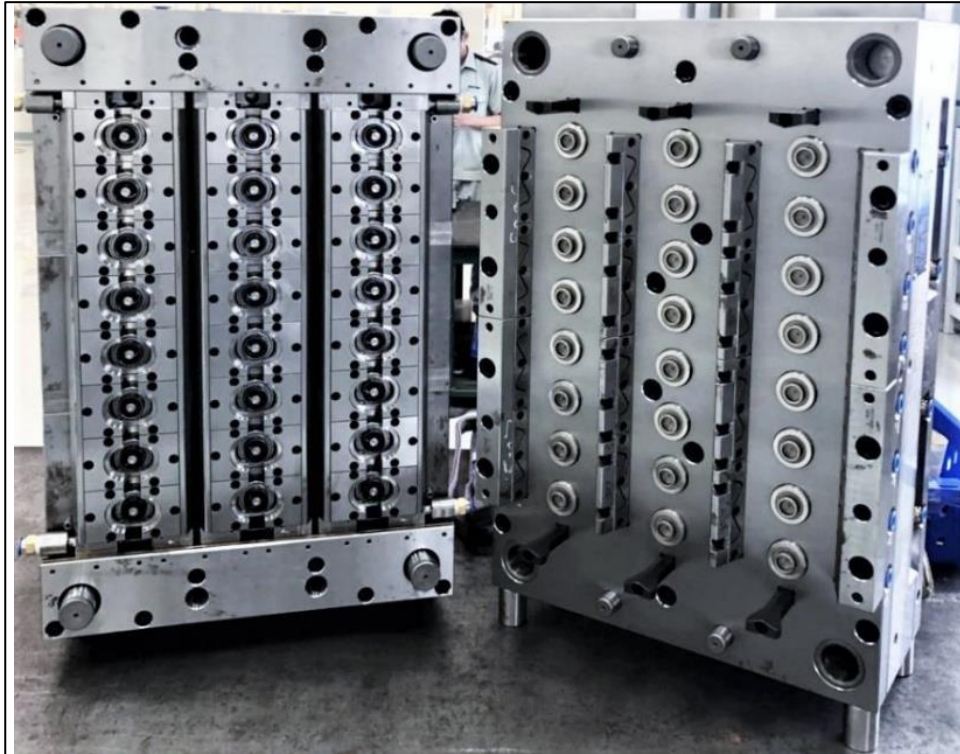

- Product : Effervescent tablets cap D31.9
- No. of cavity : 24 cav
- Resin : LDPE
- Part weight : 4.7g
- Machine: JSW ADS 180 T
- Cycle time: 24s
- Mold size: 700 x 500 x 597 (L x W x H)

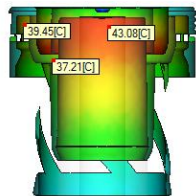
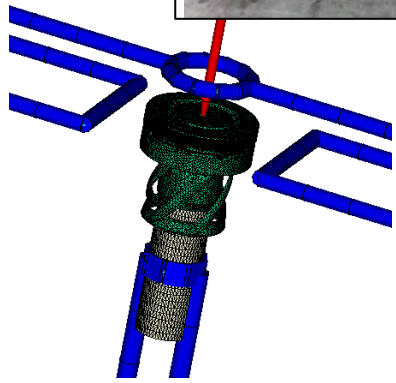



INJECTION MOLD

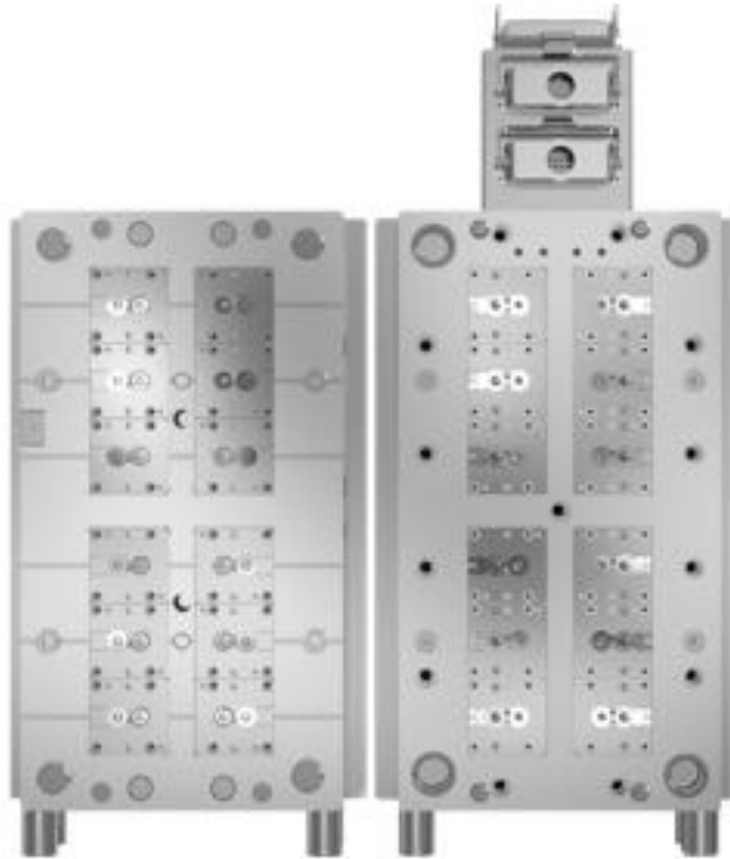

- Product : Fish Sauce Cap 12Cav
- No. of cavity : 12 cav
- Resin : HDPE
- Part weight : 2,4g
- Machine: JSW 100 T
- Cycle time: 20s
- Mold size: 650x350x468 (L x W x H)



INJECTION MOLD

- Product: Chili Sauce cap D25
- No. of cavity: 12 cav
- Resin: PP
- Part weight: 2.6g
- Machine: JSW ADS 180
- Cycle time: 20,5s
- Mold size: 910x550x495 (L x W x H)

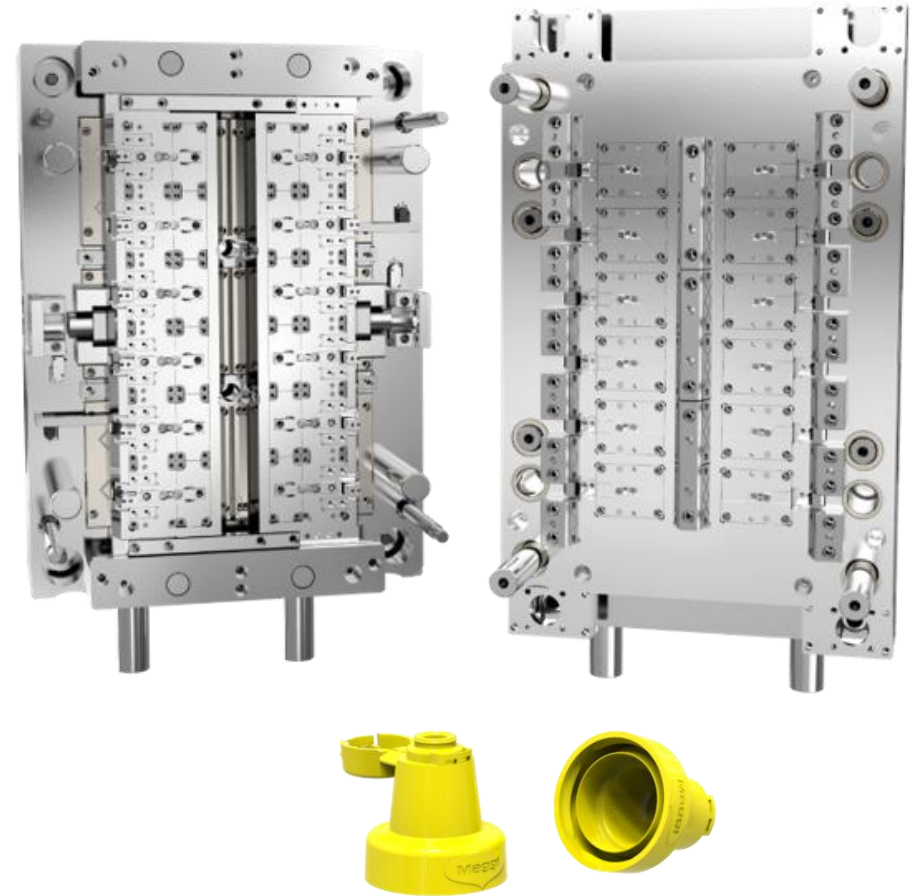



INJECTION MOLD

- Product: Soy sauce cap D30
- No. of cavity: 16 cav
- Resin: LDPE
- Part weight: 5.6g
- Machine: JSW ADS 450
- Cycle time: 20s
- Mold size: 1000x850x665 (L x W x H)

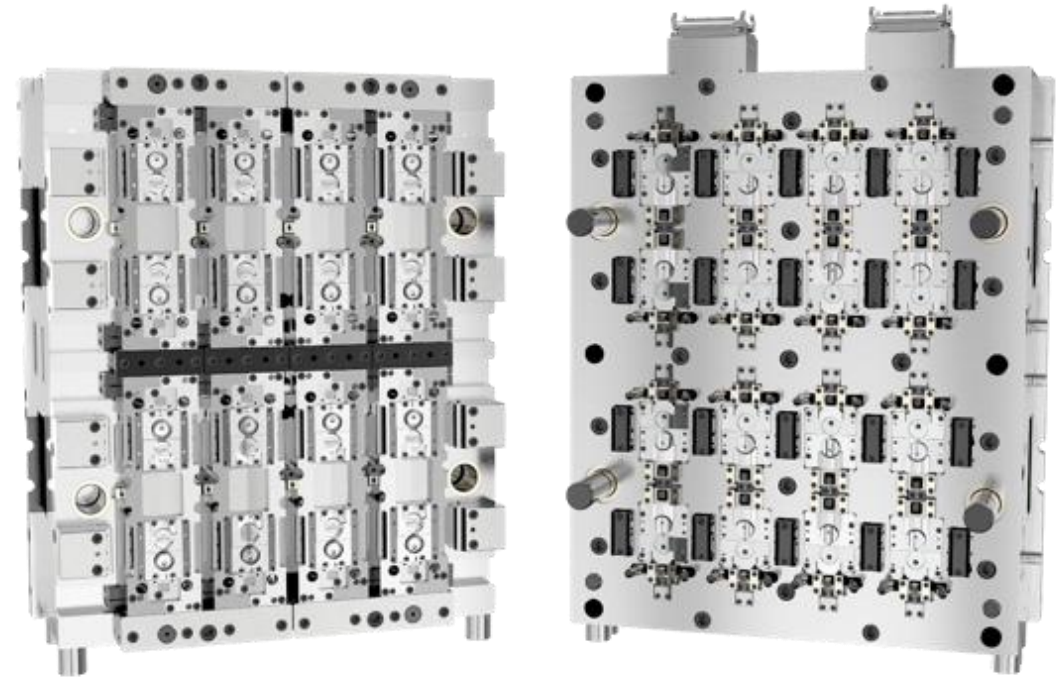



INJECTION MOLD

- Product: Edible oil fliptop cap D028 PCO1881
- No. of cavity: 16 cav
- Resin: LDPE & HDPE
- Part weight: 6.7g
- Machine: JSW ADS 180
- Cycle time: 18s
- Mold size: 750x490x521 (L x W x H)

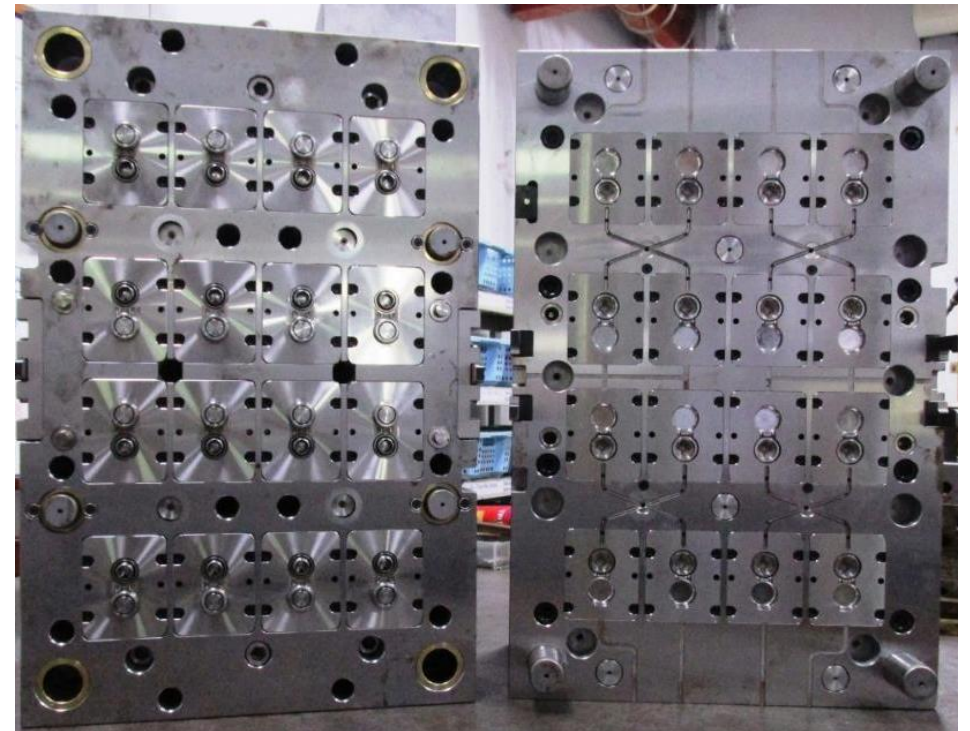



INJECTION MOLD



- Product: Fliptop 8oz Tall Snap On
- No. of cavity : 12cav
- Resin: PP
- Part weight: 13.6g
- Machine: JSW ADS 350
- Cycle time: 18s
- Mold size: 1050x700x527 (LxWxH)



INJECTION MOLD



- Product: Cap D60 stack mold
- No. of cavity: 16
- Resin: PP
- Part weight: 4.9g
- Machine: JSW ADS 110
- Cycle time: 12.5s
- Mold size: 550 x 400 x 446.8 (L x W x H)



INJECTION MOLD

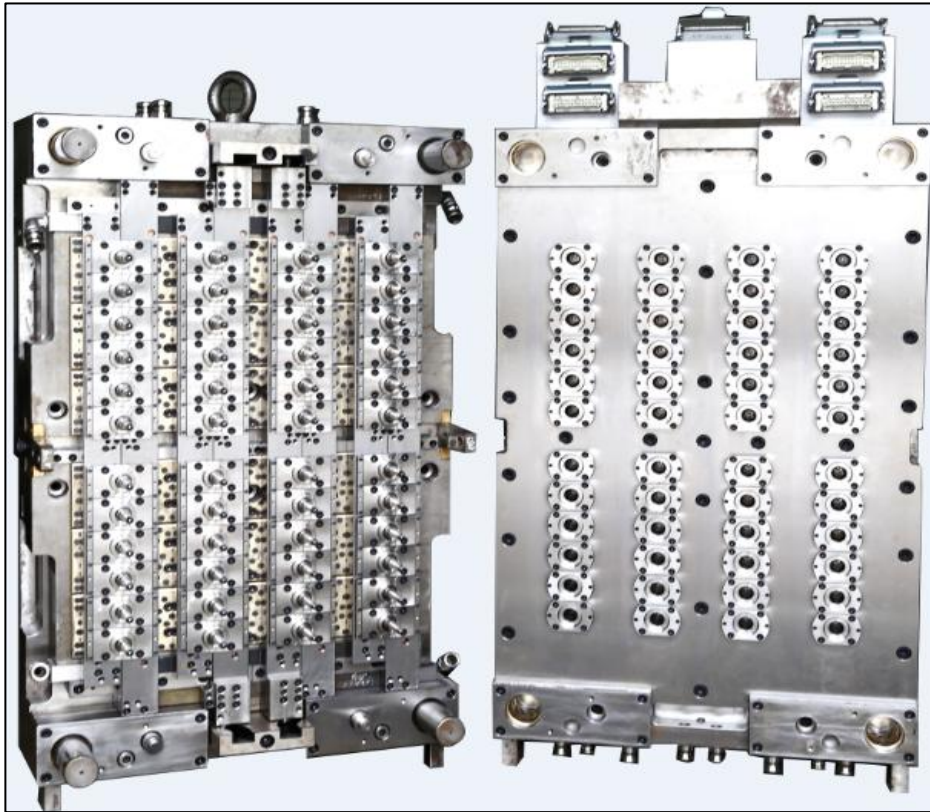

- Product: Preform D30 P30
- No. of cavity: 48cav
- No. of cavity: PET
- Part weight: 30g
- Machine: JSW ADS 450
- Cycle time: 30s
- Mold size: 1150x790x651 (L x W x H)



INJECTION MOLD

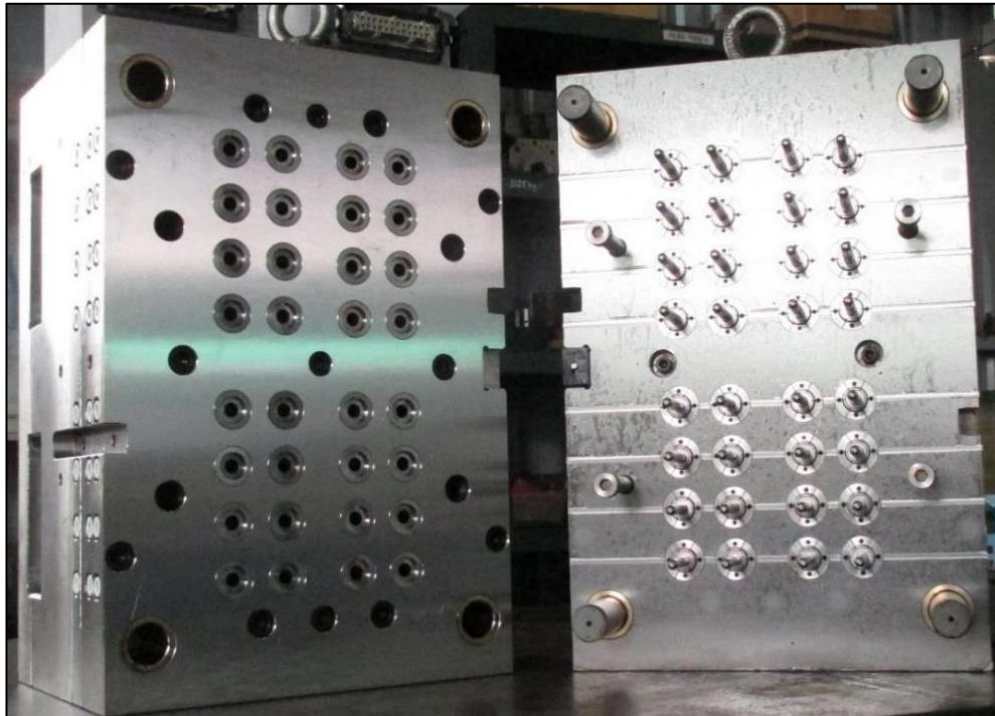

- Product: Blood tube
- No. of cavity: 32 cav
- Resin: PP
- Part weight: 2.2g
- Machine: Krauss Maffei 80
- Cycle: 8s
- Mold size: 600x400x443 (L x W x H)



BLOWING MOLD

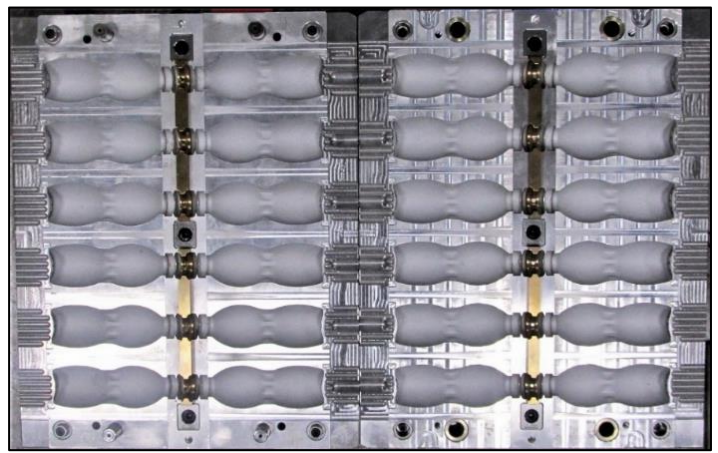

- No. of cavity: Max 14 cav
- Volume: 50ml -> 25 Litre





ISO CERTIFICATE

COMPANY MANAGEMENT SYSTEMS



bsi.
Certificate of Registration



QUALITY MANAGEMENT SYSTEM - ISO 9001:2015

This is to certify that: **DUY TAN PRECISION MOLD COMPANY LIMITED**
Lot 1, Street 1A, Tan Tao Industrial Park,
Tan Tao Ward,
Ho Chi Minh City,
Vietnam

Holds Certificate Number: **FM 721416**

and operates a Quality Management System which complies with the requirements of ISO 9001:2015 for the following scope:

The design, manufacture and supply of molds.

For and on behalf of BSI:

Michael Lam
Senior Vice President, APAC Assurance

Original Registration Date: **20/02/2020**
Latest Revision Date: **27/01/2026**



...making excellence a habit.™

This certificate was issued electronically and remains the property of BSI and is bound by the conditions of contract.
An electronic certificate can be authenticated online. Printed copies can be validated at www.bsigroup.com/ClientDirectory or telephone +44 (28) 39 200 066.
Further clarifications regarding the scope of this certificate and the applicability of ISO 9001:2015 requirements may be obtained by consulting the organization.
This certificate is valid only if provided original copies are in complete set.
Information and Contact: BSI, Kitemark Court, Davy Avenue, Knowlhill, Milton Keynes MK5 8PP. Tel: +44 845 080 9000.
BSI Assurance UK Limited, registered in England under number 7905321 at 389 Chiswick High Road, London W4 4AL, UK.
Contact Office: BSI Vietnam Headquarters - 15 Floor APC Tower, 5188 Dien Bien Phu Street, Ward 21, Binh Thanh District, Ho Chi Minh City, Vietnam. Telephone: +84 (28) 38 200 066.
A member of the BSI Group of Companies.

bsi.
Giấy Chứng Nhận



HỆ THỐNG QUẢN LÝ CHẤT LƯỢNG - ISO 9001:2015

Chứng nhận rằng: **CÔNG TY TNHH KHUÔN CHÍNH XÁC DUY TÂN**
Lô 1, Đường số 1A, Khu công nghiệp Tân Tạo,
Phường Tân Tạo,
Thành phố Hồ Chí Minh,
Việt Nam

Giữ giấy chứng nhận số: **FM 721416**

và thực hiện Hệ thống Quản lý Chất lượng phù hợp với các yêu cầu của ISO 9001:2015 cho phạm vi:

Thiết kế, gia công và cung cấp khuôn mẫu.

Đại diện cho Tập đoàn BSI:

Ông Michael Lam
Phó Chủ tịch, Dịch Vụ Đàm Bảo Khu Vực Châu Á Thái Bình Dương

Ngày đăng ký đầu tiên: **20/02/2020**
Ngày sửa đổi sau cùng: **27/01/2026**



...making excellence a habit.™

This certificate was issued electronically and remains the property of BSI and is bound by the conditions of contract.
An electronic certificate can be authenticated online. Printed copies can be validated at www.bsigroup.com/ClientDirectory or telephone +44 (28) 39 200 066.
Further clarifications regarding the scope of this certificate and the applicability of ISO 9001:2015 requirements may be obtained by consulting the organization.
This certificate is valid only if provided original copies are in complete set.
Information and Contact: BSI, Kitemark Court, Davy Avenue, Knowlhill, Milton Keynes MK5 8PP. Tel: +44 845 080 9000.
BSI Assurance UK Limited, registered in England under number 7905321 at 389 Chiswick High Road, London W4 4AL, UK.
Contact Office: BSI Vietnam Headquarters - 15 Floor APC Tower, 5188 Dien Bien Phu Street, Ward 21, Binh Thanh District, Ho Chi Minh City, Vietnam. Telephone: +84 (28) 38 200 066.
A member of the BSI Group of Companies.

bsi.
Certificate of Registration



OCCUPATIONAL HEALTH AND SAFETY MANAGEMENT SYSTEM – ISO 45001:2018

This is to certify that: **DUY TAN PRECISION MOLD COMPANY LIMITED**
Lot 1, Street 1A, Tan Tao Industrial Park,
Tan Tao Ward,
Ho Chi Minh City,
Vietnam

Holds Certificate Number: **OHS 721418**

and operates an Occupational Health and Safety Management System which complies with the requirements of ISO 45001:2018 for the following scope:

The design, manufacture and supply of molds.

For and on behalf of BSI:

Michael Lam
Senior Vice President, APAC Assurance

Original Registration Date: **20/02/2020**
Latest Revision Date: **27/01/2026**



...making excellence a habit.™

This certificate was issued electronically and remains the property of BSI and is bound by the conditions of contract.
An electronic certificate can be authenticated online. Printed copies can be validated at www.bsigroup.com/ClientDirectory or telephone +44 (28) 39 200 066.
Further clarifications regarding the scope of this certificate and the applicability of ISO 45001:2018 requirements may be obtained by consulting the organization.
This certificate is valid only if provided original copies are in complete set.
Information and Contact: BSI, Kitemark Court, Davy Avenue, Knowlhill, Milton Keynes MK5 8PP. Tel: +44 845 080 9000.
BSI Assurance UK Limited, registered in England under number 7905321 at 389 Chiswick High Road, London W4 4AL, UK.
Contact Office: BSI Vietnam Headquarters - 15 Floor APC Tower, 5188 Dien Bien Phu Street, Ward 21, Binh Thanh District, Ho Chi Minh City, Vietnam. Telephone: +84 (28) 38 200 066.
A member of the BSI Group of Companies.



DUYTAN PRECISION MOLD

CONTACT US



+84 28 3754 5418



+84 28 3754 5416



info@duytanmold.com



<http://duytanmold.com>



HEAD OFFICE

Block 1, 1A Road, Tan Tao
Industrial Zone, Tan Tao Ward, Ho
Chi Minh City, VietNam



SCAN ME
Introduction Video



THANK YOU!